

HAUG Ionization - for the elimination of electrostatic charges



S-Line ionizing bar EI SL

Thanks to its state-of-the-art ionization technology, the HAUG EI SL ionizing bar is setting new standards: Ensuring an optimal neutralizing effect, it eliminates electrostatic charges during roll, sheet and web processing (ill. 1 and 2).

Special features and advantages

The extensive development of the S-Line ionizing bar offers many advantages, especially to the application technology.

- **Modern tailor-made industrial design:**
The round construction of the ionizing bar, in combination with the special HAUG brackets (photo 1), permits the exact axial adjustment to the material web. The ionizing bar so always offers the optimal amount of positive and negative ions to the material to be neutralized.
- **Tailor-made technology:**
The outstanding HAUG engineering technology stands for high quality. This technology prevents disturbances as well as loss of production and produces a considerable saving of both time and expenses over the medium term.
- **Tailor-made accessories:**
The HAUG System X-2000 coaxial high-voltage plug connection offers unique benefits. The gastight high-voltage plug can be connected to HAUG power packs without tools. The flexible coaxially shielded cable is used to connect the ionizing bar to the voltage supply source (ill. 3 and 4).



EI SL / CI SL

Passive ionizer

The passive ionizer CI SL completes active ionizing units. It is an efficient pre-ionizer, especially for high charges. Passive ionizers are metallic pins which are connected to earth. When a passive ionizer is moved towards a charged material, an ion-producing corona discharge is induced in the pins of the ionizer. The neutralizing effect of a passive ionizer is particularly recommended in combination with an active ionizing unit. The passive ionizer works independently of power supply.

ill. 1

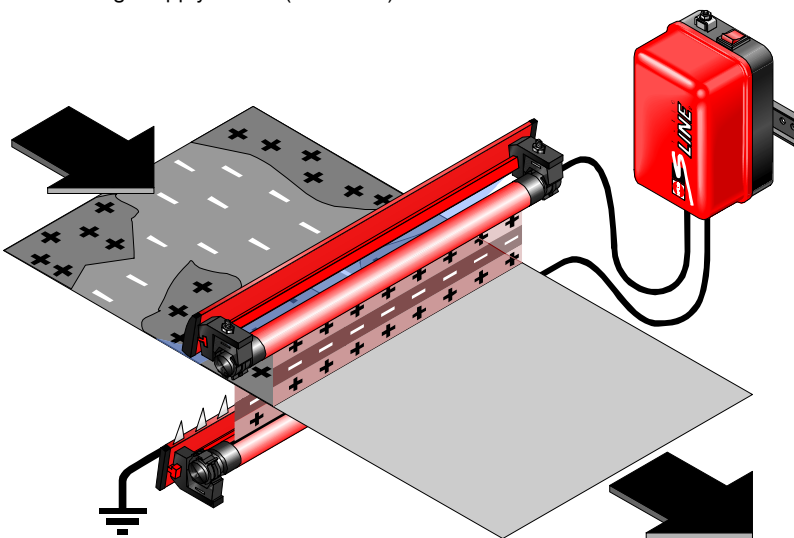

EI SL

photo 1



ill. 2

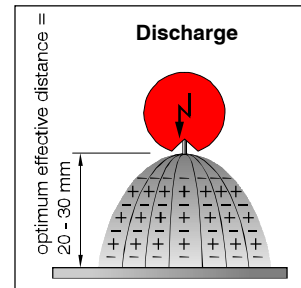

Applications

Today, HAUG ionizing bars are indispensable to the packaging, film/foil, printing and textile industries as well as for many other industrial applications.

Recommendations

The EI SL ionizing bar is suitable for feed speeds up to 100 m/min.

In order to ensure high efficiency and trouble-free production, we recommend that two ionizing bars be installed (above and below the material web. ill. 1), particularly during foil processing.

ill. 3



ill. 4



S-Line ionization system

The S-Line Power Pack EN SL provides the ionizer with approx. 7 – 8 kV alternating current by means of the integrated high-voltage transformer. The various ionizers are connected to the power pack.

The S-Line LC power pack comes with a signal lamp to monitor the high voltage.

HAUG GmbH & Co. KG

Germany

Friedrich-List-Str. 18
D-70771 Leinf.-Echterdingen
Phone: +49 711 / 94 98-0
Telefax: +49 711 / 94 98-298

www.haug.de
E-mail: info@haug.de

HAUG Biel AG

Switzerland

Johann-Renfer-Str. 60
CH-2500 Biel-Bienne 6
Phone: +41 32 / 344 96 96
Telefax: +41 32 / 344 96 97

www.haug-ionisation.com
E-mail: info@haug-biel.ch

Static Line - Ionizing bar EI SL / CI SL





Brackets

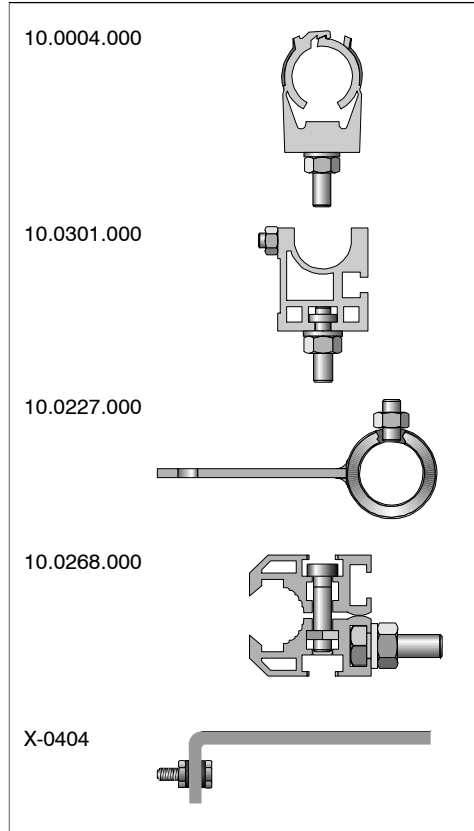

EI SL

Technical data EI SL

Typen:	EI SL length 200 mm	Order-No.: 03.8025.002
	EI SL length 300 mm	Order-No.: 03.8025.003
	EI SL length 400 mm	Order-No.: 03.8025.004
	EI SL length 500 mm	Order-No.: 03.8025.005
	EI SL length 600 mm	Order-No.: 03.8025.006
	EI SL length 800 mm	Order-No.: 03.8025.008
	EI SL length 1000 mm	Order-No.: 03.8025.010
	EI SL length 1200 mm	Order-No.: 03.8025.012
	EI SL length 1400 mm	Order-No.: 03.8025.014
	EI SL length 1500 mm	Order-No.: 03.8025.015
	EI SL length 1600 mm	Order-No.: 03.8025.016
	EI SL length 1700 mm	Order-No.: 03.8025.017
	EI SL length 1800 mm	Order-No.: 03.8025.018
	EI SL length 1900 mm	Order-No.: 03.8025.019
	EI SL length 2000 mm	Order-No.: 03.8025.020

Diameter: 20 mm

Length: available from 150 to 2500 mm (total length)
Standard bar lengths incl. high-voltage cable
available ex-stock.

Operating temperature: +5 °C to +45 °C

Storage/transport temperature: -15 °C to +60 °C

Optimum effective distance: 20 – 30 mm

Effective length: bar length - 140 mm

Smallest bending radius (cable): R 50

Subject to technical changes!

Accessories

Passive ionizer CI SL	Order-No.: 12.0002.000
Passive ionizer CI SL, with 100 MΩ/2 W	Order-No.: 12.0002.007
Additional blower "Jet Streamer" JS SL	Order-No.: 11.0000.000
Klick-Zack	Order-No.: 10.0004.000
Bracket	Order-No.: 10.0301.000
Bracket	Order-No.: 10.0227.000
Bracket	Order-No.: 10.0268.000
Bracket	Order-No.: X-0404 a.o.

Suitable power packs

Connectable lengths (ionizing unit incl. high-voltage cable):

EN SL / EN SL LC max. 5 m

EN SL RLC max. 10 m

EN 8 / EN 8 LC max. 18 m

Multistat max. 18 m

EN 70 / EN 70 LC max. 2 x 18 m

