

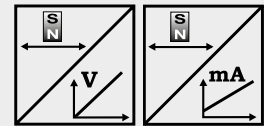

POSICHRON® position sensor in round profile

- Protection class IP64
- Measurement range 0 ... 100 to 0 ... 5750 mm
- Absolute position measurement
- Contactless
- Absolutely wearless and maintenance-free for the positioning magnet
- Analog output



Specifications	Output	Voltage Current
	Resolution	Refer to output specification
Sampling rate	Up to 1 kHz, depending on the measurement range	
Linearity	Ranges >500 mm: L10 = ±0.10 % f.s. L02 = ±0.02 % f.s. Ranges ≤500 mm: L10 = ±0.5 mm L02MM = ±0.2 mm	
Repeatability	±3 µm	
Housing material	AlMgSi1 / Zn / V4A	
Protection class	IP64 (with mating connector only)	
Shock	EN 60068-2-27:2010, 50 g 11 ms, 100 shocks	
Vibration	EN 60068-2-6:2008, 20 g 10 Hz-2 kHz, 10 cycles	
Connection	Connector M12, 8 pin / cable 2 m	
EMC, temperature	Refer to output specification	

**Order code PCRP21
1 channel**



Model name

Measurement range (in mm)

100 ... 5750 (in 10 mm increments)
other lengths upon request

Output

- U1 = 0 ... 10 V signal conditioner
- U1/H = U1 with Alarm_HOLD (see page 10)
- U2 = 0.5 ... 10 V signal conditioner
- U2/U; U2/H = U2 with Alarm_LOW; U2 with Alarm_HOLD (see page 10)
- U8 = 0.5 ... 4.5 V signal conditioner
- U8/U; U8/H = U8 with Alarm_LOW; U8 with Alarm_HOLD (see page 10)
- I1 = 4 ... 20 mA signal conditioner (3 wire)
- I1/U; I1/H = I1 with Alarm_LOW; I1 with Alarm_HOLD (see page 10)

Function and characteristics output

- P1A = Position Magnet 1, increasing
- P1D = Position Magnet 1, decreasing
- PMU = Start value, direction & end value adjustable by the customer

Linearity

L02 / L02MM / L10 (for definition see "Specifications" above)

Connection

- M12 = Connector M12, 8 pin
- KAB2M = Cable, standard length 2 m, other lengths upon request

Order code mounting set (see page 7)

PCRP21-BFS4

Order Code PCRP21
2 channel, configurable

PCRP21 - [] - [] - [] - [] - [] - []

Model name

Measurement range (in mm)
 100 ... 5750 (in 10 mm increments)
 other lengths upon request

Output

U1 = 0 ... 10 V signal conditioner
 U1/H = U1 with Alarm_HOLD (see page 10)
 U2 = 0.5 ... 10 V signal conditioner
 U2/U; U2/H = U2 with Alarm_LOW; U2 with Alarm_HOLD (see page 10)
 U8 = 0.5 ... 4.5 V signal conditioner
 U8/U; U8/H = U8 with Alarm_LOW; U8 with Alarm_HOLD (see page 10)
 I1 = 4 ... 20 mA signal conditioner (3 wire)
 I1/U; I1/H = I1 with Alarm_LOW; I1 with Alarm_HOLD (see page 10)

Function and characteristics output 1

P1A = Position magnet 1, increasing
 P1D = Position magnet 1, decreasing
 DA = Difference magnet 1/2, increasing (2 magnets required)
 DD = Difference magnet 1/2, decreasing (2 magnets required)

Function and characteristics output 2

P2A = Position magnet 2, increasing
 P2D = Position magnet 2, decreasing
 DA = Difference magnet 1/2, increasing
 DD = Difference magnet 1/2, decreasing } 2 magnets required

VZx.x = Velocity with direction detection (with 1 magnet only)

VZx.x = Velocity in steps of 0.1 m/s			
<u>Example: VZ1.5</u>	towards start position		towards end position
	-1.5 m/s	0	+1.5 m/s
Output U2:	0.5 V	5.25 V	10 V
Output I1:	4 mA	12 mA	20 mA

VAx.x = Velocity without direction detection (with 1 magnet only)

VAx.x = Velocity in steps of 0.1 m/s			
<u>Example: VA1.5</u>	towards start position		towards end position
	-1.5 m/s	0	+1.5 m/s
Output U2:	10 V	0.5 V	10 V
Output I1:	20 mA	4 mA	20 mA

Linearity
 L02 / L02MM / L10 (for definition see "Specifications" above)

Connection

M12 = Connector M12, 8 pin
 KAB2M = Cable, standard length 2 m, other lengths upon request

1. Order example: PCRP21 - 1000 - U2 - P1D - L10 - M12
 Round profile, measurement range 1000 mm, 1 voltage output 0.5 ... 10 V (U2)
 Output 1: Position magnet 1, decreasing signal (P1D)
 Output 2: Not used

2. Order example: PCRP21 - 1000 - I1 - P1A - P2D - L10 - M12
 Round Profile, measurement range 1000 mm, 2 current outputs 4 ... 20 mA (I1)
 Output 1: Position magnet 1, increasing signal (P1A)
 Output 2: Position magnet 2, decreasing signal (P2D)

Order code position magnets (see page 7)

PCMAG ...

Order code mating connecting cable (see page 14)

KAB-...M-M12/8F/G-LITZE



POSICHRON® position sensor in round profile

- Protection class IP64
- Measurement range 0 ... 100 to 0 ... 5750 mm
- Absolute position measurement
- Wear- and maintenance-free
- Superior shock and vibration resistance
- Absolutely wear free and maintenance-free
- Synchronous serial interface (SSI)

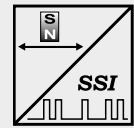

Specifications		
Output		Synchronous serial interface (SSI)
Resolution		5, 10, 20, 50, 100 µm
Sampling rate		Up to 1 kHz, depending on the measurement range
Linearity		Ranges >500 mm: L10 = ±0.10 % f.s. L02 = ±0.02 % f.s. Ranges ≤500 mm: L10 = ±0.5 mm L02MM = ±0.2 mm
Repeatability		±3 µm
Housing material		AlMgSi1 / Zn / V4A
Protection class		IP64 (with mating connector only)
Shock		EN 60068-2-27:2010, 50 g 11 ms, 100 shocks
Vibration		EN 60068-2-6:2008, 20 g 10 Hz-2 kHz, 10 cycles
Connection		Connector M12, 8 pin / cable 2m
EMC, temperature		Refer to output specification

Order Code PCR21

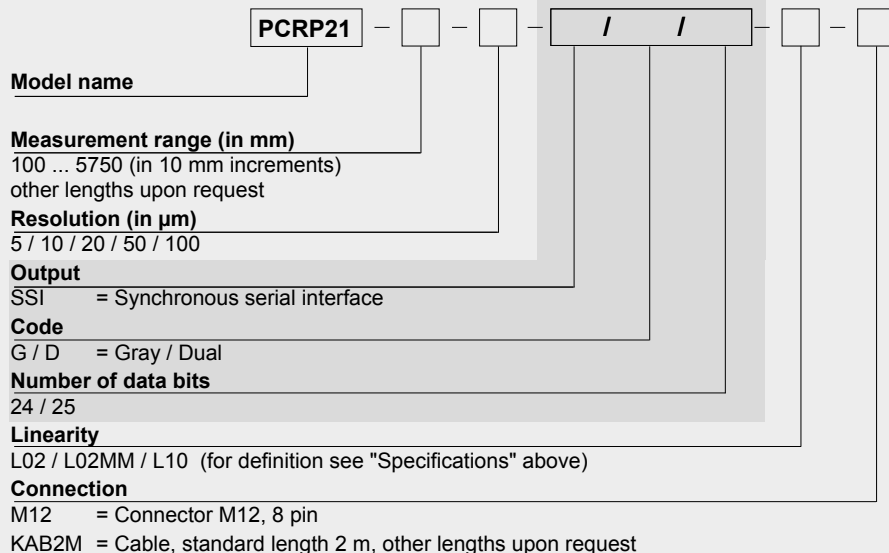

Order code mounting set (see page 7)

PCRP21-BFS4

Order code position magnets (see page 7)

PCMAG ...

Order code mating connecting cable (see page 14)

KAB-...M-M12/8F/G-LITZE

Order example: PCR21 - 1000 - 5 - SSI/G/24 - L10 - M12



POSICHRON® position sensor in round profile

- Protection class IP64
- Measurement range 0 ... 100 to 0 ... 5750 mm
- Absolute position measurement
- Contactless
- Absolutely wear free and maintenance-free
- CANOpen bus

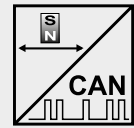

Specifications	Output	CANopen bus; CAN SAE J1939
	Resolution	50 µm
	Sampling rate	Up to 1 kHz, depending on the measurement range
	Linearity	Ranges >500 mm: L10 = ±0.10 % f.s. L02 = ±0.02 % f.s. Ranges ≤500 mm: L10 = ±0.5 mm L02MM = ±0.2 mm
	Repeatability	±3 µm
	Housing material	AlMgSi1 / Zn / V4A
	Protection class	IP64 (with mating connector only)
	Shock	EN 60068-2-27:2010, 50 g 11 ms, 100 shocks
	Vibration	EN 60068-2-6:2008, 20 g 10 Hz-2 kHz, 10 cycles
	Connection	5 pin socket M12
EMC, temperature	Refer to output specification	

Order Code PCR21

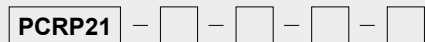

Model name

Measurement range (in mm)

100 ... 5750 (in 10 mm increments)
other lengths upon request

Output

CANOP = CANopen bus
CANOP/R = CANopen-Bus with integrated terminating resistance
CANJ1939 = CAN SAE J1939

Linearity

L02 / L02MM / L10 (for definition see "Specifications" above)

Connection

M12/CAN = Connector M12, 5 pin

Order code mounting set (see page 7)

PCRP21-BFS4

Order code position magnet (see page 7)

PCMAG ...

Order code bus cable (see page 15)

KAB-...M-M12/5F/G-M12/5M/G - CAN

Order example: PCR21 - 1000 - CANOP - L10 - M12/CAN

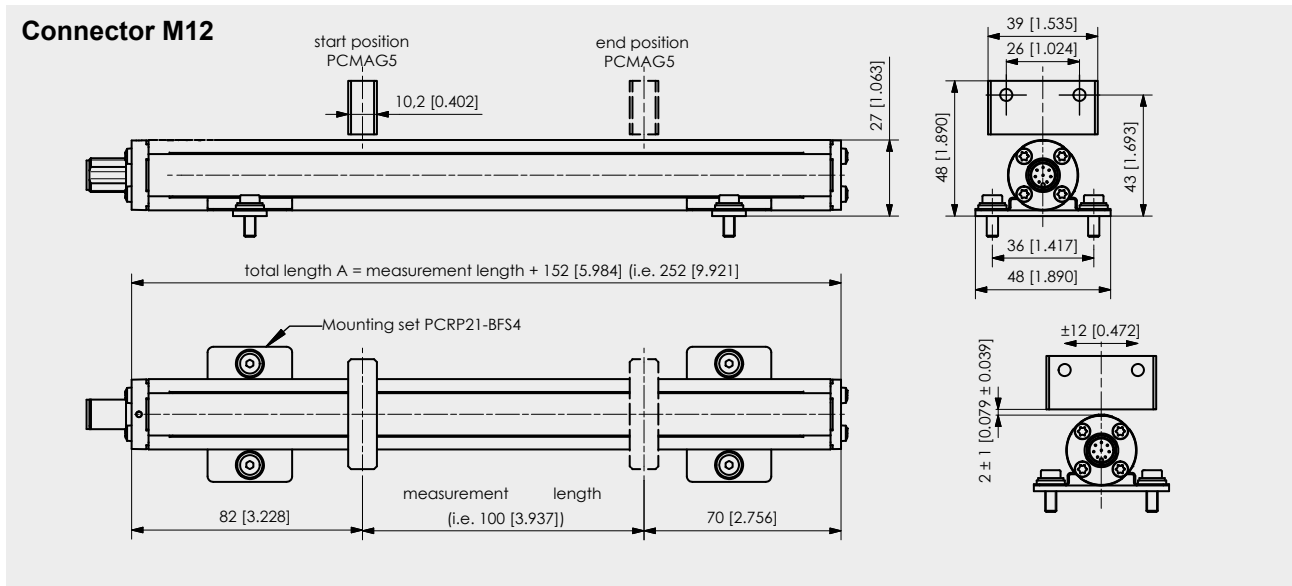

Dimensions in mm [inch]

Dimensions informative only. For guaranteed dimensions consult factory.

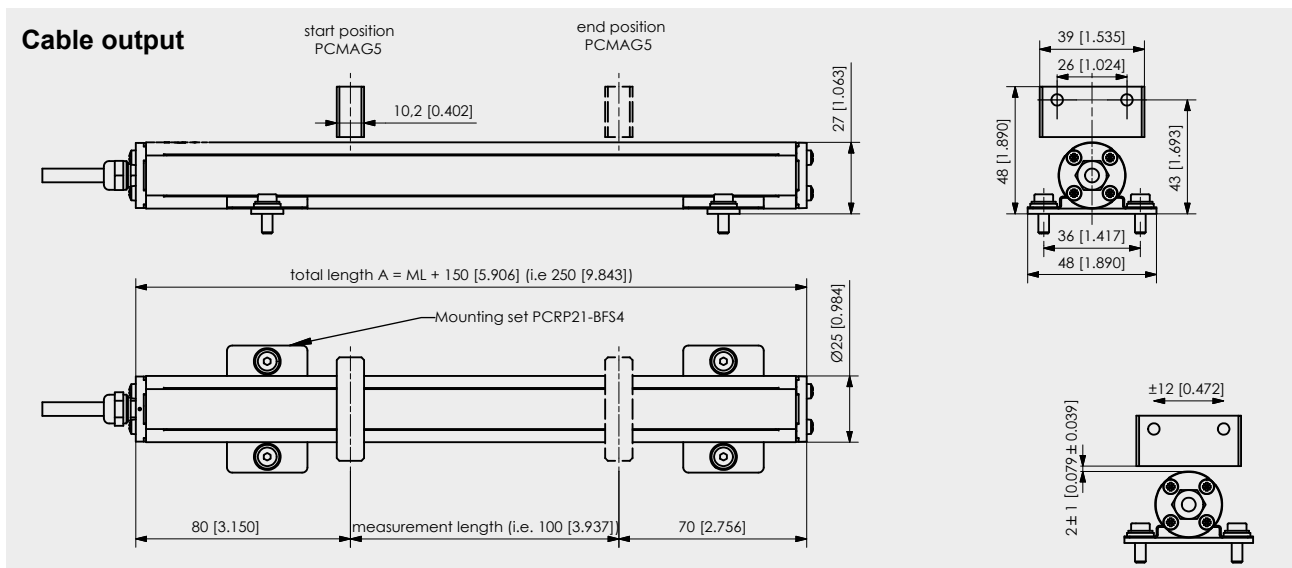

Dimensions in mm [inch]

Dimensions informative only. For guaranteed dimensions consult factory.

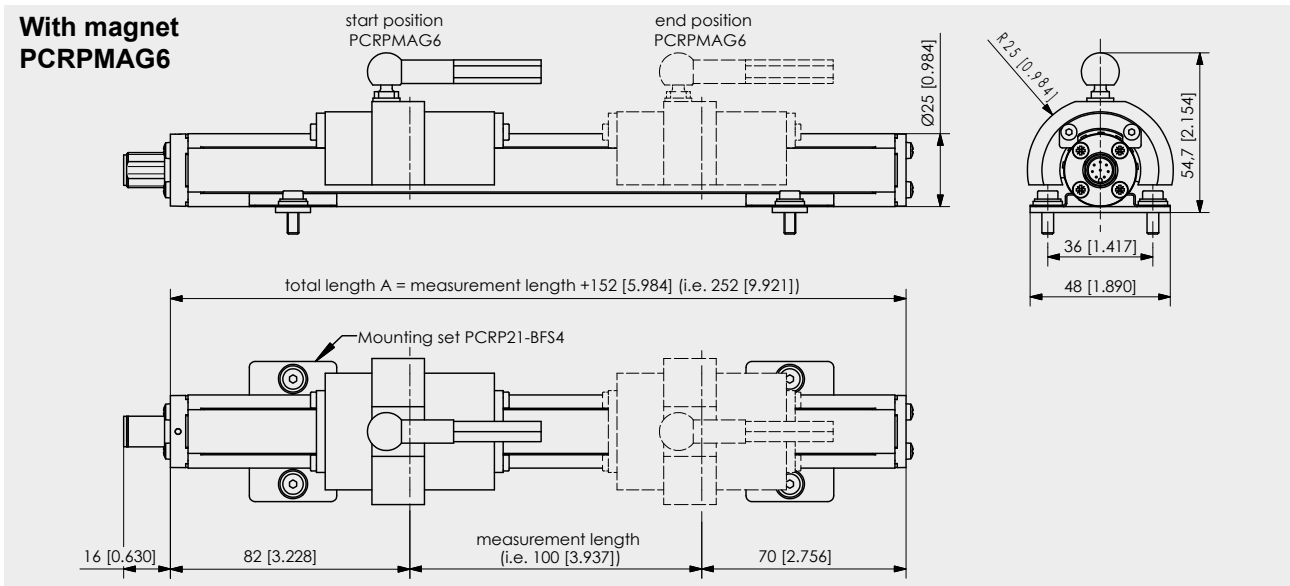

Dimensions in mm [inch]

Dimensions informative only. For guaranteed dimensions consult factory.

PCRP21-BFS4
Mounting set for
PCRP21

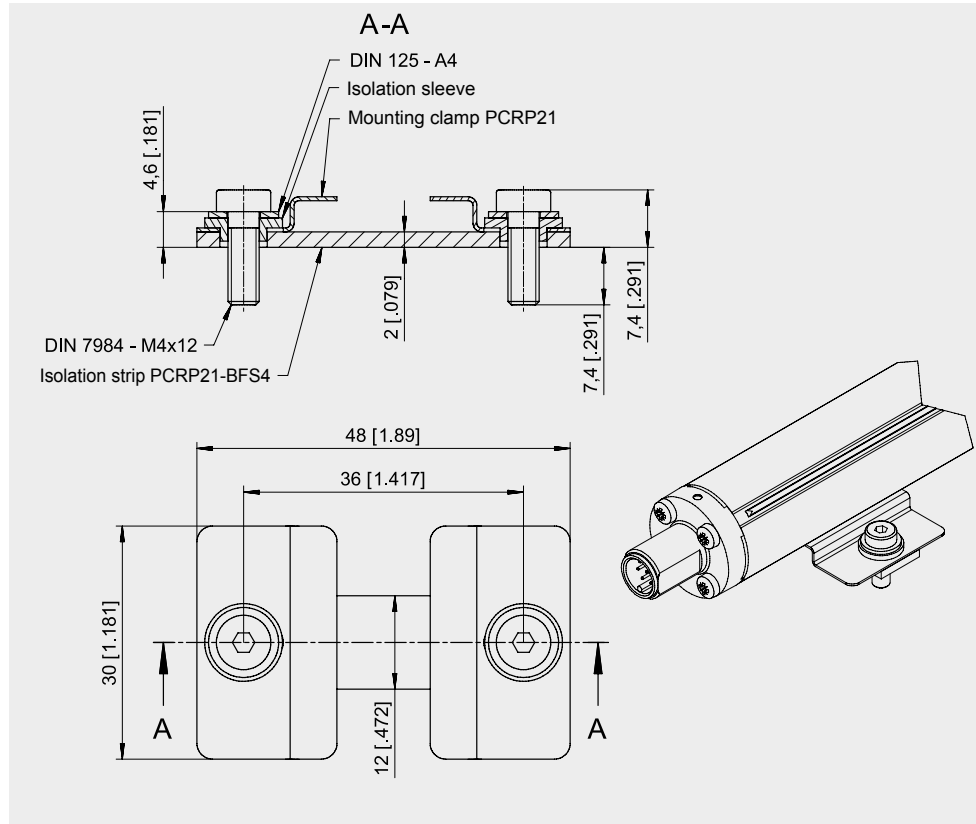

PCMAG5
Standard magnet

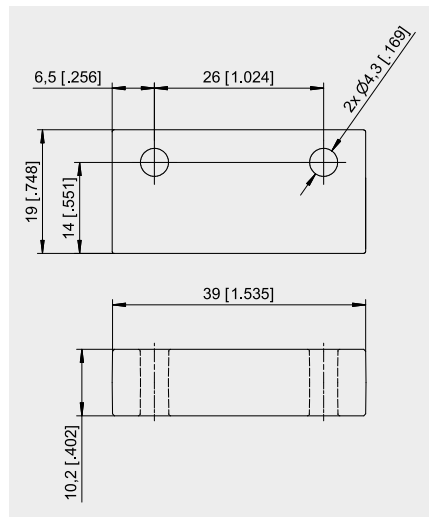

Dimensions in mm [inch]

Dimensions informative only.
For guaranteed dimensions consult factory.

PCRPMAG6
Guided magnet slider
for PCR21 with internal
position magnet

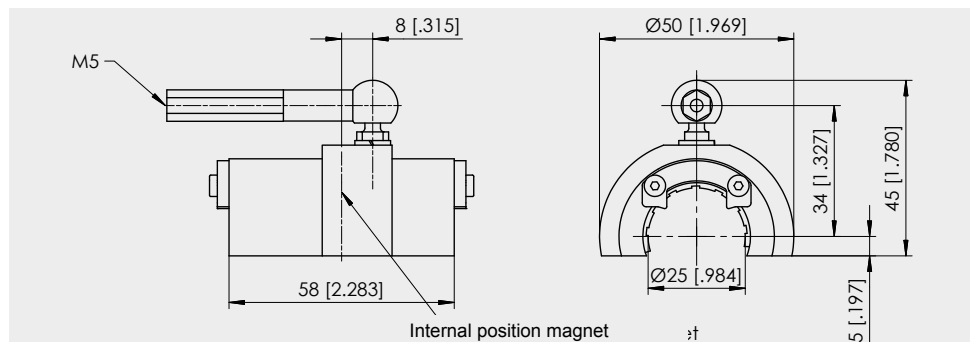

Not to be used for a large number of operation cycles!

U1, U2, U8 Voltage output 	Excitation voltage	U1: 18 ... 36 V DC; U2: 18 ... 36 V DC; U8: 10 ... 36 V
	Excitation current	Typ. 35 mA, 80 mA max.
	Output voltage	U1: 0 ... 10 V DC; U2: 0.5 ... 10 V DC; U8: 0.5 ... 4.5 V DC
	Output current	2 mA max.
	Output load	> 5 kΩ
	Resolution	16 bit f.s., min. 10 μm
	Stability (temperature)	±50 x 10 ⁻⁶ / °C f.s.
	Protection	Reverse polarity, short circuit
	Output noise	0.5 mV _{RMS}
	Operating temperature	-40 ... +85 °C
EMC	EN 61326-1:2013	

Signal diagram

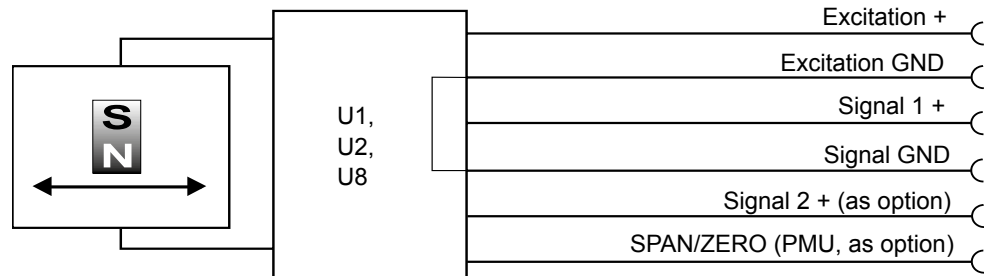

I1 Current output (3 wire) 	Excitation voltage	18 ... 36 V DC (10 ... 36 V for R _L ≤ 250Ω)
	Excitation current	Typ. 60 mA, 80 mA max.
	Load resistor	350 Ω max.
	Output current	4 ... 20 mA, 30 mA max (at failure)
	Resolution	16 bit f.s., min. 10 μm
	Stability (temperature)	±50 x 10 ⁻⁶ / °C f.s.
	Protection	Reverse polarity, short circuit
	Output noise	0.5 mV _{RMS}
	Operating temperature	-40 ... +85 °C
	EMC	EN 61326-1:2013

Signal diagram

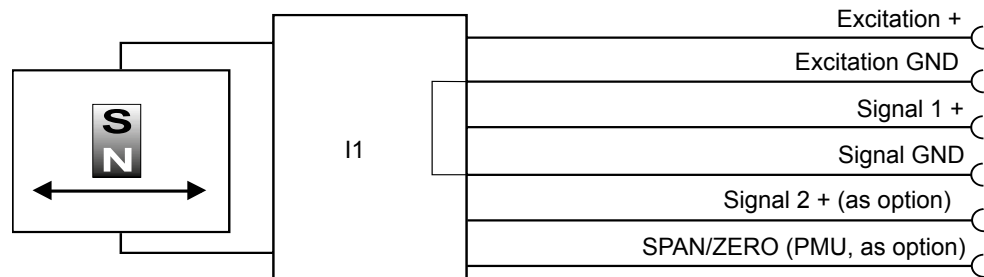

Connector M12, 8-pin

Signal wiring

Signal	Plug connection	Cable connection
Excitation +	1	white
Excitation GND	2	brown
Signal 1 +	3	green
Signal GND	4	yellow
Signal 2 + (optional*)	5	grey
SPAN/ZERO (PMU** only, optional)	6	pink

View to the sensor connector

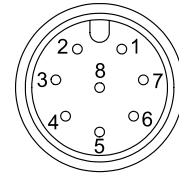

* When using multiple magnets the distance between two magnets must be min. 70 mm to identify the single magnets definitely. ** Description page 10

Connector M12, 5-pin

Signal wiring

Signal	Plug connection
Excitation +	1
Signal 1 +	2
GND	3
Signal 2 + (optional*)	4
PMU** (optional)	5

View to the sensor connector

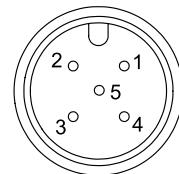

* When using multiple magnets the distance between two magnets must be min. 70 mm to identify the single magnets definitely. ** Description page 10

Connector M8, 4-pin

Signal wiring

Signal	Plug connection
Excitation +	1
Excitation GND	2
Signal +	3
PMU** (optional)	4

View to the sensor connector

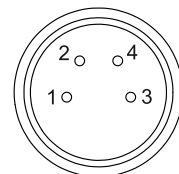

* When using multiple magnets the distance between two magnets must be min. 70 mm to identify the single magnets definitely. ** Description page 10

Option - PMU for analog output U1, U2, U8 and I1

Programming of the start and end value by the customer:

The option PMU allows to program the start value and the end value of the output range by a programming signal SPAN/ZERO available at the connector. This Signal SPAN/ZERO must be connected with GND via a push button, then position magnet of the sensor must be moved to the start resp. end position. Pushing the button between 2 and 4 seconds sets the actual position as start position, pushing the button more than 5 seconds sets the actual position as end position. The values will be stored and are available after switching off the sensor.

To reset the sensor to the factory values the button must be pushed for longer than two seconds when the sensor is switched on.

Diagnostic on analog outputs

Behaviour of the analog signal output in case of error

In case of error (magnet missing or outside the measuring range) the analog output signal will assume a state according to the following options:

Alarm_HIGH

The output voltage resp. the output current is at HIGH level (overrange).

Alarm_LOW

The output voltage resp. the output current is at LOW level (underrange).

Alarm_HOLD

The output voltage resp. the output current will keep the last valid state.

	Alarm_HIGH (standard)	Alarm_LOW (.../U)	Alarm_HOLD (.../H)
U1	$U_{out} \geq 10,5 \text{ V}$	—	keeps last valid state (Order code U1/H)
U2	$U_{out} \geq 10,5 \text{ V}$	$U_{out} < 0,25 \text{ V}$ (Order code U2/U)	keeps last valid state (Order code U2/H)
U8	$U_{out} \geq 10 \text{ V}$	$U_{out} < 0,25 \text{ V}$ (Order code U8/U)	keeps last valid state (Order code U8/H)
I1	$I_{out} \geq 21 \text{ mA}$	1,5 ... 2 mA (Order code I1/U)	keeps last valid state (Order code I1/H)

Error signal for SSI output

If the sensor cannot detect a magnet the position value will assume the maximum value (0xFFFFFFFF).

Synchronous serial interface SSI

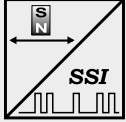

Output	RS422
Excitation voltage	10 ... 36 V DC, residual ripple 10 mV _{SS}
Excitation current	Typ. 80 mA, 150 mA max.
Clock frequency	100 kHz ... 1 MHz
Code	Gray code, dual code
Resolution	≥ 5 μm
Delay between pulse trains	>25 μs
Stability (temperature)	±50 x 10 ⁻⁶ / °C f.s.
Operating temperature	-40 ... +85 °C
EMC	EN 61326-1:2013

Description

The data transmission takes place by means of the two signals CLOCK and DATA. The processing unit (PLC, microcomputer) sends pulse sequences which clock the data transmission at the required transfer rate. With the first falling edge of the pulse sequence the position of the sensor is recorded and stored. The following rising edges control the bit-by-bit transfer of the data word. After a delay time the next new position information can be transmitted.

Data format
(Train of 26 pulses)

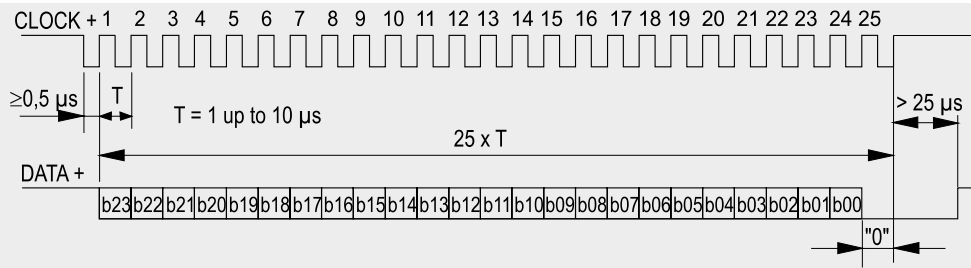

Signal diagram

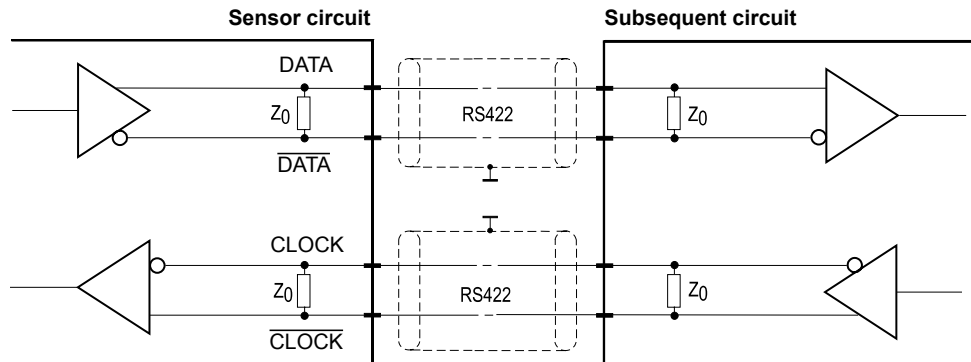

Cable length	Baud rate
50 m	100-1000 kHz
100 m	100-300 kHz

Note:
Extension of the cable length will reduce the maximum transmission rate.
The signals CLOCK/CLOCK and DATA/DATA must be connected in a twisted pair cable, common shielded.

Signal wiring

Signal	Plug connection	Cable connection
Excitation +	1	white
Excitation GND	2	brown
CLOCK	3	green
CLOCK	4	yellow
DATA	5	grey
DATA	6	pink

View to sensor connector



Error indication see page 10.

Description CANopen interface with process data for position and cam functions, programmable are preset, resolution, filtering and cam switching points.

Interface CANOP 	Communication profile	CANopen CiA 301 V 4.02, Slave
	Encoder profile	Encoder CiA 406 V 3.2
	Error Control	Node Guarding, Heartbeat, Emergency Message
	Node ID	Adjustable via LSS or via object dictionary
	PDO	4 TxPDO, 0 RxPDO, no linking, static mapping
	PDO Modes	Event-/Time triggered, Remote-request, Sync cyclic/acyclic
	SDO	1 server, 0 client
	CAM	8 cams
	Certified	Yes
	Transmission rates	50 kBaud to 1 MBaud, adjustable via LSS or via object dictionary
	Nodes	127 max.
	Bus connection	M12 connector, 5 pins
	Integrated bus terminating resistor	120 Ω (option)
Bus, galvanic isolated	No	

Specifications	Excitation voltage	18 ... 36 V DC
	Excitation current	Typ. 20 mA for 24 V, max. 80 mA
	Number of position magnets	1 ... 4
	Resolution	50 μm
	Measuring rate	1 kHz (asynchronous)
	Stability (temperature)	±50 x 10 ⁻⁶ / °C f.s.
	Repeatability	1 LSB
	Operating temperature	-40 ... +85 °C
	Protection	Reverse polarity, short circuit
	Dielectric strength	500 V (V AC, 50 Hz, 1 min.)
	EMC	EN 61326-1:2013

When using multiple magnets the distance between two magnets must be min. 70 mm to identify the single magnets definitely.

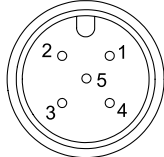
Signal wiring	Signal	Plug connection	View to sensor connector 
	Shield	1	
	Excitation +	2	
	GND	3	
	CAN-H	4	
	CAN-L	5	

Interface J1939 	CAN specification	ISO 11898, Basic and Full CAN 2.0 B
	Transceiver	24V-compliant, not isolated
	Communication profile	SAE J1939
	Baud rate	250 kbit/s
	Internal termination resistor	120 Ω (option)
	Address	Default 247d, configurable

NAME Fields	Arbitrary address capable	0	No
	Industry group	0	Global
	Vehicle system	7Fh (127d)	Non specific
	Vehicle system instance	0	
	Function	FFh (255d)	Non specific
	Function instance	0	
	ECU instance	0	
	Manufacturer	145h (325d)	Manufacturer ID
	Identity number	0nnn	Serial number 21 bit

Parameter Group Numbers (PGN)	Configuration data	PGN EF00h	Proprietary-A (PDU1 peer-to-peer)
	Process data	PGN FFnnh	Proprietary-B (PDU2 broadcast); nn Group Extension (PS) configurable

Specifications	Excitation voltage	18 ... 36 V DC
	Excitation current	Typ. 20 mA for 24 V, max. 80 mA
	Measuring rate	1 kHz (asynchronous)
	Stability (temperature)	±50 x 10 ⁻⁶ / °C f.s.
	Repeatability	1 LSB
	Operating temperature	-40 ... +85 °C
	Protection	Reverse polarity, short circuit
	Dielectric strength	500 V (V AC, 50 Hz, 1 min.)
	EMC	EN 61326-1:2013

When using multiple magnets the distance between two magnets must be min. 70 mm to identify the single magnets definitely.

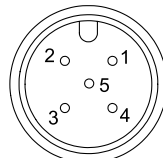
Signal wiring	Signal	Plug connection	View to sensor connector 
	Shield	1	
	Excitation +	2	
	GND	3	
	CAN-H	4	
	CAN-L	5	

**Connector cable
M12, 5-pin
shielded**

The 5-lead shielded cable is supplied with a mating 5-pin 90° M12 connector at one end and 5 wires at the other end. Available lengths are 2 m, 5 m and 10 m. Wire: cross sectional area 0.34 mm².

Order code:

KAB - XM - M12/5F/W - LITZE
IP69K: KAB - XM - M12/5F/W/69K - LITZE

Length in m

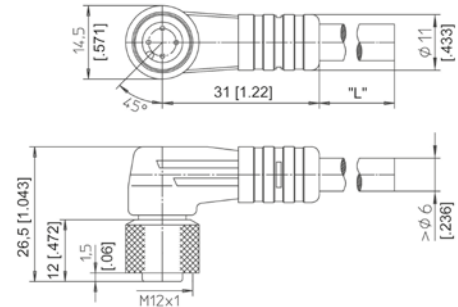

**Connector cable
M12, 5-pin
shielded**

The 5-lead shielded cable is supplied with a mating 5-pin M12 connector at one end and 5 wires at the other end. Available lengths are 2 m, 5 m and 10 m. Wire: cross sectional area 0.34 mm².

Order code:

KAB - XM - M12/5F/G - LITZE
IP69K: KAB - XM - M12/5F/G/69K - LITZE

Length in m

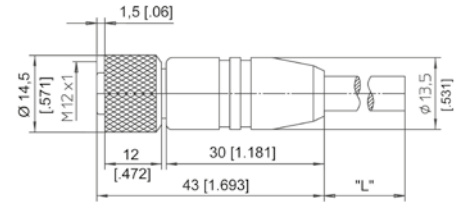

Signal wiring M12, 5-pin	Plug connection / Cable connection				
	1	2	3	4	5
	brown	white	blue	black	grey

**Connector cable
M12, 8-pin
shielded**

The 8-lead shielded cable is supplied with a mating 8-pin 90° M12 connector at one end and 8 wires at the other end. Available lengths are 2, 5 and 10 m. Wire: cross sectional area 0.25 mm².

Order code:

KAB - XM - M12/8F/W - LITZE
IP69K: KAB - XM - M12/8F/W/69K - LITZE

Length in m

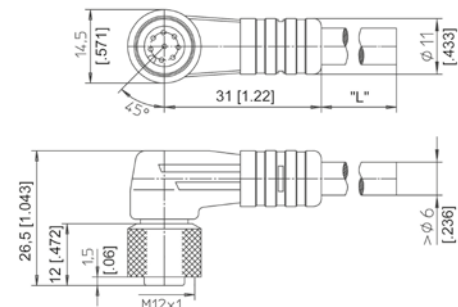

**Connector cable
M12, 8-pin
shielded**

The 8-lead shielded cable is supplied with a mating 8-pin M12 connector at one end and 8 wires at the other end. Available lengths are 2, 5 and 10 m. Wire: cross sectional area 0.25 mm².

Order code:

KAB - XM - M12/8F/G - LITZE
IP69K: KAB - XM - M12/8F/G/69K - LITZE

Length in m

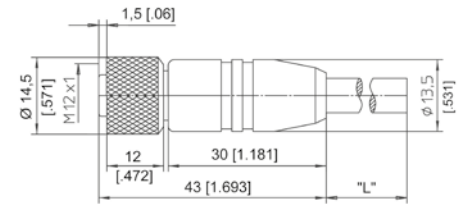

Signal wiring M12, 8-pin	Plug connection / Cable connection							
	1	2	3	4	5	6	7	8
	white	brown	green	yellow	grey	pink	blue	red

Connector/bus cable
M12, 5-pin
CAN bus
shielded

The 5-lead shielded cable is supplied with a female 5-pin M12 connector at one end and a male 5-pin M12 connector at the other end. Available lengths are 0.3 m, 2 m, 5 m and 10 m.

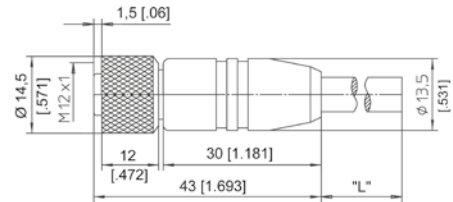

Order code:

KAB - XM - M12/5F/G - M12/5M/G - CAN

IP69K: KAB - XM - M12/5F/G/69K - M12/5M/G/69K - CAN

Length in m ↑

T-piece for bus cable
M12, 5-pin
CAN bus

Order code:

KAB - TCONN - M12/5M - 2M12/5F - CAN

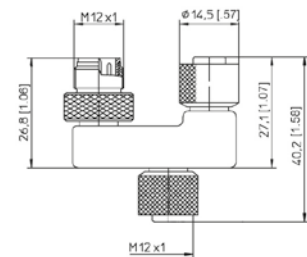

Terminating
resistance
M12, 5-pin
CAN bus

Order code:

KAB - RTERM - M12/5M/G - CAN

