

CANopen ABSOLUTE SINGLE TURN ENCODERS, CHO5 RANGE

CHO5, the new generation of CANopen absolute single turn encoders :

- Through hollow shaft version Ø14mm, with reduction hubs in aluminium of 6, 8, 10 and 12 mm,
- 58mm encoder, extra-flat,
- Robustness and excellent resistance to shocks / vibrations,
- High protection level IP65,
- High performances in temperature -20°C to 85° (-30°C option),
- Universal power supply from 5 to 30 Vdc,
- High resolutions up to 8192 points pre turn (2¹³).

CANopen

DS 301 V4.02
DS 406 V3.1



CHO5_14 connection BCR (radial M23)

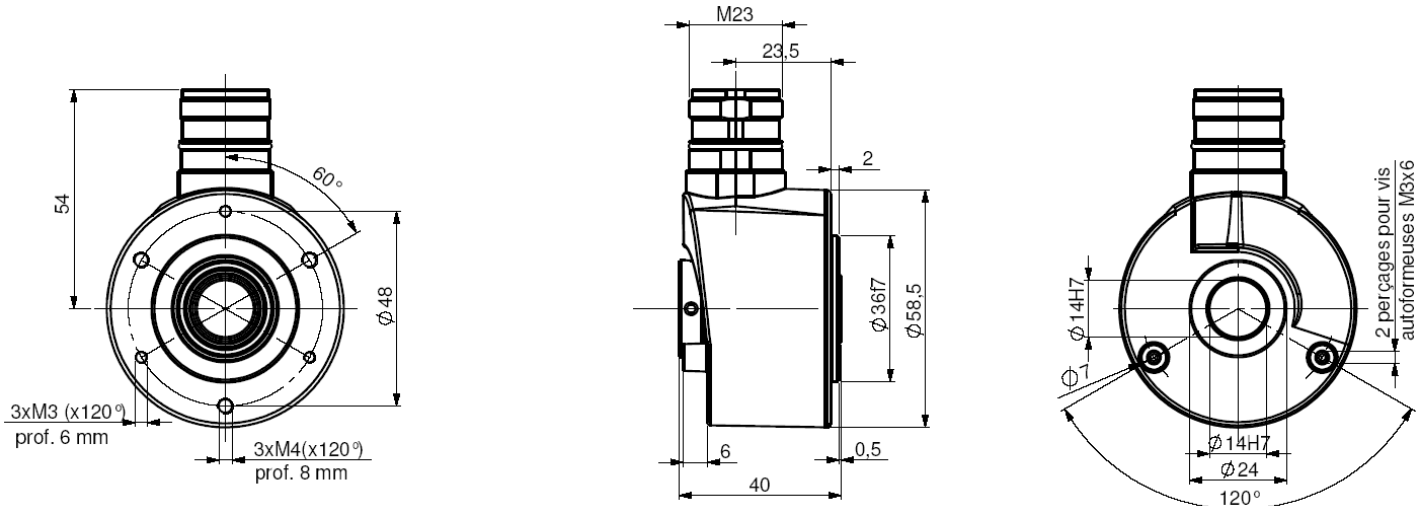

CHO5_14 connection BCR (radial M23), DAC 9445/015* mounted on the body

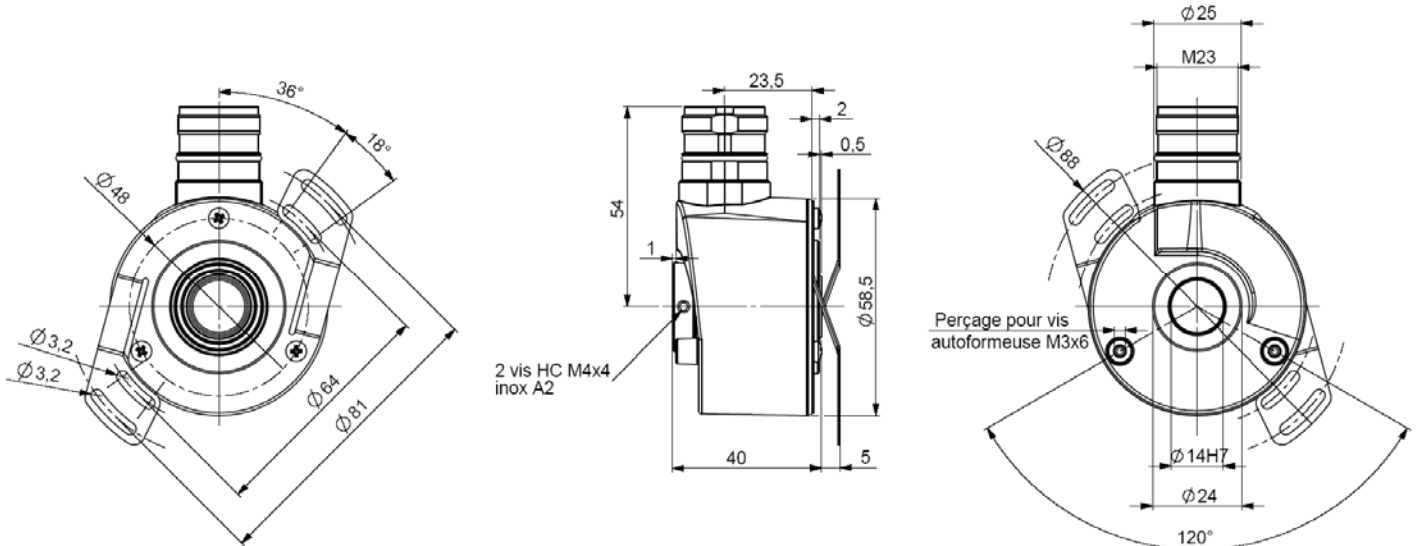

* Accessory to be ordered separately

Material	Cover : zinc alloy
	Body: aluminium
	Shaft : stainless steel
Bearings	6 803 serie
Maximal loads	Axial : 20 N
	Radial : 50 N
Shaft inertia	≤ 2,2.10 ⁻⁶ kg.m ²
Torque	≤ 6.10 ⁻³ N.m
Permissible max. speed	9 000 min ⁻¹
Continuous max. speed	6 000 min ⁻¹
Shaft seal	Viton

Shocks (EN60068-2-27)	≤ 500 m.s ⁻² (during 6 ms)
Vibrations (EN60068-2-6)	≤ 100 m.s ⁻² (10 ... 2 000 Hz)
EMC	EN 61000-6-4, EN 61000-6-2
Isolation	500V (1min)
Encoder weight (approx.)	0,300 kg
Operating temperature	- 20 ... + 85°C (encoder T°)
Storage temperature	- 40... + 85°C
Protection(EN 60529)	IP 65
Torque (ring pressure screw)	nominal: 1.5 N.m, break: 2.0 N.m
Theoretical mechanical lifetime 10 ⁹ turns (F _{axial} / F _{radial})	
10N / 25N : 230	20N / 50N : 29

CANopen

ELECTRICAL CHARACTERISTICS

Power supply	5 – 30Vdc
Introduction	< 1 s
Consumption (without load)	< 50mA (at 24Vdc)
Accuracy	± ½ LSB (13 bits)

Programmable parameters

Resolution: defines the resolution per revolution (0 to 8 192),

Transmission speed : programmable from 10kbaud (1000m) to 1 Mbaud (40 m) ; value per default: 20 Kbaud,

Address: define the software address of the encoder on the bus (1 to 127, value by default: id = 1),

Direction : define the direction of count of the encoder,

RAX : defines the value of its preset position (non turning shaft),

CAM: Low and High Limits.

Communication modes

3 modes are available to interrogate the encoder :

POLLING mode: (Response to a RTR message): The position value is only given upon request (SDO mode),

CYCLIC mode: the encoder transmits its position in an asynchronous manner. The frequency of the transmission is defined by the programmable cyclical timer register from 0 to 65 535 ms,

SYNCHRO mode: the encoder transmits its position on a synchronous demand by the master.

CANOPEN CONNECTION

1	2	3	4	5	6	7	8, 9, 11	10	12
Reserved	CAN LOW	CAN GND	Reserved	Reserved	Reserved	CAN HIGH	Reserved	0V	+ 5/30Vdc

Pinout 3 (CAN GND) and 10 (0V) are connected together (intern the encoder).

Nota : Refer to the bus standards for the maximal derivation length.

ORDERING CODE (Special versions upon request, for ex. special flanges/electronics/connections...)

	Shaft Ø	Power supply	Output stage	Code	Resolution	Connection	Connection orientation
CHO5	14 : 14mm Reduction hubs available	P : 5 to 30Vdc	BB : CANopen	B: Binary	13 : 8192 ppoints per revolution (2 ¹³)	BC: M23 12 pinouts clockwise	R : radial
CHO5 _	14 //	P	BB	B //	13 //	BC	R

Made in France